

«Forteza»

**RADIO-WAVE  
SECURITY DETECTOR**

**«Forteza M-40»**

User manual

Klaipeda

## Content

1	Description and operation .....	4
1.1	Application .....	4
1.2	Technical specifications .....	6
1.3	Components.....	7
1.4	Design and operation.....	<b>7.Error! Bookmark not defined.</b>
1.5	Marking .....	11
1.6	Packaging .....	<b>Error! Bookmark not defined.</b>
2	Intended use.....	<b>Error! Bookmark not defined.</b>
2.1	Activation and running-in .....	12
2.2	Operating.....	17
3	Maintenance .....	19
4	Storage, transportation and utilization .....	19
5	Acceptance certificate.....	19
6	Manufacturer's Guarantees.....	19

This operation manual contains information concerning application, design, operation, technical specifications, structure of the radio-wave security detector “Forteza M-40” and its modifications (further “Detector”), and installation and maintenance instructions necessary for the most effective usage of its technical potential. There are several modifications of the Detector with different numbers in the name (01, 02, and so on) which were specially designed for certain customers and can differ in additional certificates, in the case color and structure. All the information and differences for each variant are presented in the relevant documents of this manual.

The abbreviations, used in this manual:

- PSU - power supply unit
- DZ - detection zone
- IAK - installation assembly kit
- JB - junction box
- PK-U - universal control tester

# 1 Description and operation

## 1.1 Application

1.1.1 The Detector is an automatic one-position radar for a human crossing the zone of detection (DZ) detection, and is meant as a security system device used out-of doors as well as inside.

1.1.2 The Detector is designed for out-of-doors exploitation if it is installed under a shelter or a screen. It is possible to use the Detector inside, if there is intensive induced or natural ventilation (storehouses, docks, etc.), and if masking with radio-transparent materials (plastic of up to 2 mm thick, textiles).

1.1.3 The Detector forms DZ of “blind” type, it is recommended for roofs, building walls and other objects protection. The Detector can be also used for perimeters protection (along fences for example). The Detector provides detection even of a creeping intruder.

1.1.4 The Detector can be used to protect horizontal areas, the DZ plane should be oriented parallel to the ground surface (“square” – type). In this case, narrow direction diagram (with certain regulation in the vertical plane) helps to exclude false alarms on dogs and other small animals, moving in the DZ.

1.1.5 The rough DZ look in two planes and maximal distance is presented in picture 1.1. DZ minimal width (radiation diagram) is in the plane parallel to the case axis.

DZ size can be regulated.

**Attention! The Detector in the operating mode “blind” has a zone of weak detection at the distance of 3 m from the detector.**

1.1.6 The Detector forms alarm reports (alarm – further) by output circuit OUT breaking, and by light indication if:

- DZ is crossed by a human (in the “blind” mode);
- A human moves in the direction perpendicular to the radiation direction, at the distance of up to 3 m (in the “square” mode);
- The control impulse is given to the TEST input;
- Sabotage is tried by radiation shielding with radio-reflecting or radio- absorbing materials in the close zone or under masking radiation influence;
- The supply voltage disappears or is getting lower up to  $(9,6 \pm 0,5)$  V.

1.1.7 The Detector forms alarm reports of unauthorized entering by the output circuit TAMPER breaking if the junction box (JB) cover is open.

1.1.8 The detector receives power supply from a constant-current source with rated voltage form 12 to 24 V, and pulse amplitude less than 0.03 V. If the Detector is installed out-of-doors, use reserving power supply unit (RPSU-12/02), JB can be not used.

Exploitation conditions:

- “Forteza M-40” working temperature range is from  $- 40$  to  $+ 65^{\circ}\text{C}$ ;
- Air humidity can be up to 100 % , if temperature is  $+ 25^{\circ}\text{C}$ .

1.1.9 The Detector provides continuous day-and-night work, functionality and excludes false alarms if:

- There is precipitation influence (rain, snow) of up to 30 mm/sec. intensity;
- There is solar radiation influence;
- There is wind of up to 20 m/sec. velocity influence;
- The grass cover height is up to 0.2 m.

1.1.10 The Detector is stable to the following interferences influence:

- Single small animals or birds of a cat size moving in the DZ;
- Cargo transport moving parallel to the DZ axis more than 2 m distance far from the axis (“blind” variant), and with set maximum of DZ length.
- A human moving parallel to the DZ axis more than 1 m far from the axis (“blind” variant), and with set maximum of DZ length.
- Cargo transport moving perpendicular to the DZ axis at the distance 75% more than the set detector range.
- Induced voltage of striking with the peak value of current up to 50 A and up to 1 msec. duration;
- USB-stations radiation with diapason of 433 MHz and cell phone radiation at the distance more than 0.5 m far from the transceiver.

1.1.11 The Detector has an automatic and remote control of operation, sabotage protection (by radiation shielding with objects brought in the close (“dead”) zone.

1.1.12 The Detector has possibility of limited regulation by control devices, placed in the JB. The Detector provides regulation and displaying all the parameters and signals by the universal control tester (PK-U).

1.1.13 The Detector is protected from polarity reversal of supply voltage because of the staff false actions, and from voltage impulses of up to 1000 V and duration of up to 1 msec., induced in the connection lines during storm.

1.1.14 The constructive detector’s design is dust and splash proofed.

1.1.15 It is possible to install several detectors parallel to each other but at more than 2 m distance far.

## 1.2 Technical specifications

1.2.1 Detector's technical specifications are given in table 1.1

Table 1.1

Parameter	Value
A moving human detected speed range, m/sec.	from 0,1 to 8,0
DZ length with maximal distance, m, more than	40
DZ maximal width in the plane perpendicular to the case axis (with maximal distance), m, less than	1
DZ maximal width in the plane parallel to the case axis (with maximal distance), m, more than	25
DZ length with minimal distance, m, less than	12
Working voltage range, V	from 10,2 to 30
“Forteza M-40” consumption current, mA, less than:	
- supply voltage - 12 V	70
- supply voltage - 24 V	45
Readiness time after power supply switched on, sec., less than	30
Signal parameters, switched by output circuit contacts:	
- direct or alternating current, mA, less than;	100
Amplitude voltage, V, less than	72
TEST signal parameters:	
- circuit consumption current, mA, less than;	5
- impulse voltage, V;	8-30
- impulse duration, sec., more than	0,4
Alarm duration, sec., more than	2
Working frequency, MHz	24150 ± 100
Transceiver overall size with the bracket and screen, mm, less than	90x95x302
Detector's mass in the package, kg, less than	1,6
Detector's average working time, years, more than	8
Average trouble-free life, hours, more than	60000
Trouble possibility, leading to a false alarm, for 1000 hours, less than	0,01

### 1.3 Components

#### 1.3.1 Detector's parts are given in table 1.2

Table 1.2

Nam and abbreviation	Quantity	Notes
Detector "Forteza M-40" set consists of: a) transceiver – 1it. b) protective screen – 1it. c) retaining spring – 1it. d) installation assembly kit (IAK) consists of: - support board – 1it. - screw 6x40 – 2it. - dowel Ø10x50 – 2it. - bolt M6x10 – 2it. - washer Ø6 – 2it. - bent washer Ø6 – 2it. - clamp 78-101 – 2it.	1 it.	
Junction box JB-U1 consists of: - block JB-U1 – 1it. - support board – 1it. - screw 5x10 – 2it. - washer Ø5 – 2it. - bent washer Ø5 – 2it. - clamp 78-101 – 1it.	1 it.*	
Reserving power supply unit RPSU-12/02	1 it.*	* - delivered instead of JB, agreed in the order.
Universal control tester (PK-U)	1 it.	Delivered by a special order
User manual	1 it.	
Passport	1 it.	

### 1.4 Design and operation

#### 1.4.1 Operating principle

The Detector is a Doppler radar with ability of range correction the signal from moving targets, on the base of frequency modulation of the transmitted signal. The main difference of the detector, using the Doppler effect, is practically unchanging sensitivity inside the DZ; so the signal, appearing during an intruder moving in the DZ, is practically the same close to the detector as well as at maximal distance far from it. The signal from a small animal, moving near the detector (3 m far from it, in the height where DZ borderline touches the ground surface, for example), will be considerably weaker than a signal from an intruder moving in the DZ 40 m far from the Detector. That makes it possible to exclude false alarms while a small animal moving, if the detection threshold is correctly chosen.

Detector has two variants of application: "blind" and "square". The "blind" variant provides optimal parameters for detection an intruder moving perpendicular the DZ plane. The "square" variant is optimal for detection an intruder moving in the DZ plane in the

direction perpendicular to the radiation direction, and provides comparatively better noise-resistance to the short signals.

Delivered Detector has the following settings:

- variant – «blind»;
- detector range – «40 m»;
- threshold – «0 dB».

Detector range has three versions (20, 30, 40m), the threshold has three variants (-3, 0, 3 dB), you may chose any by pushing the control button in the JB. LED indicator in the JB shows the chosen settings and the coming signal level during adjusting. In the initial and constantly working **alarm indication mode**, the indicator displays:

- alarm reports (light from 2 to 30 sec.);
- trouble reports, including: supply voltage reduction (lower than 10.2 V); one of the basic transceiver functioning parts breaking; transceiver, “got spotted” by powerful radio interference sources (light more than 30 sec.);
- periodic interferences of any type (short flash – 0,1 sec.).

To go to the **Detector range, threshold choice modes** and back to the **alarm indication mode** – hold the control button for more than 3 sec. if you do not use the control button for 10 min., the Detector will go to the initial **alarm indication mode** automatically. The control devices usage see in the respective points of the article “detector regulation and approbation”.

To make the detector operation parameters regulation more precise and easy – do it with PK-U. PK-U can also check and change the detector’s mode, determine the supply voltage value. PK-U has alarms audible indication, which is very convenient for the Detector operating control.

Universal control tester (PK-U) provides detectors of “Forteza M-40” type setting, it has an LCD display which is very informative, and this makes the usage easier. PK-U description is given in its passport.

**The Detector’s constructive distinctive feature, which provides the detector original operating properties, is a very narrow antennae direction diagram in the plane parallel to the transceiver case axis.** This feature serves to increase resistance to the objects moving close to the DZ axis. DZ form is given in picture 1.1.

Note – DZ minimal width is in the plane parallel to the case axis.

#### 1.4.2 Detector’s design

The transceiver is a one block case with dust-and-splash proof surface. The Detector’s construction is given in picture 1.2. The JB construction is shown in picture 1.3. As the case basic material plastic, reinforced with glass-fiber, is used, this provides its high durability and firmness. The cable, connecting the transceiver and JB, is protected by the stainless spiral wrap hose of anti-vandal type. The protective screen provides water protection during heavy rains and solar radiation with possible heating up to + 65° C (in the dry tropical climate).

The JB commutation devices location and marking are shown in picture 1.3.

The bracket construction provides separate adjusting (transceiver’s direction regulation) relative to the transceiver’s axis and the bracket’s regulation part axis, located parallel to the bracket base. The transceiver is installed on the tube with IAK-1, consisting of an adapter plate and two ties. The tube recommended diameter is from 50 to 90 mm.

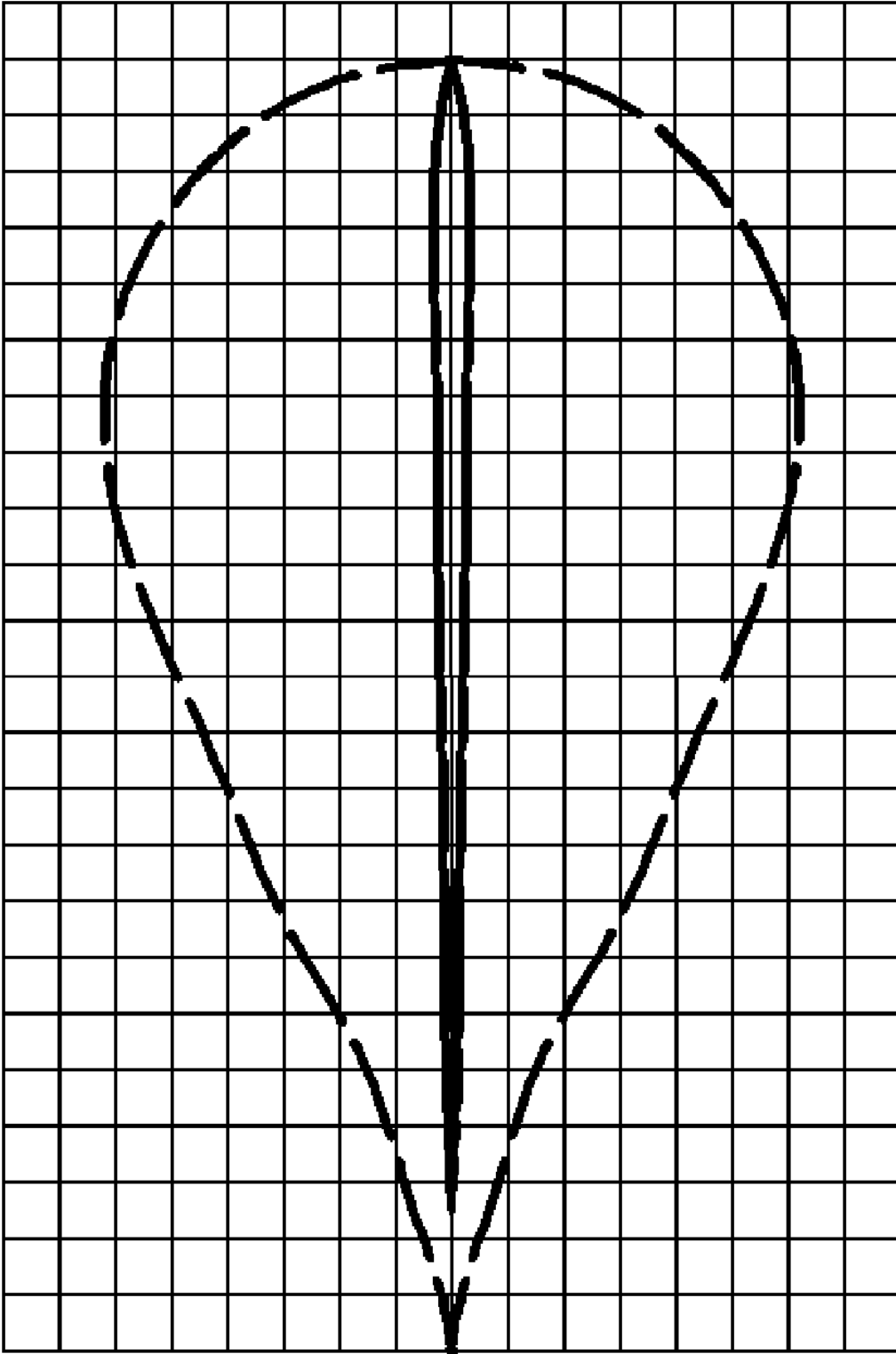

Picture 1.1 – approximate DZ form.

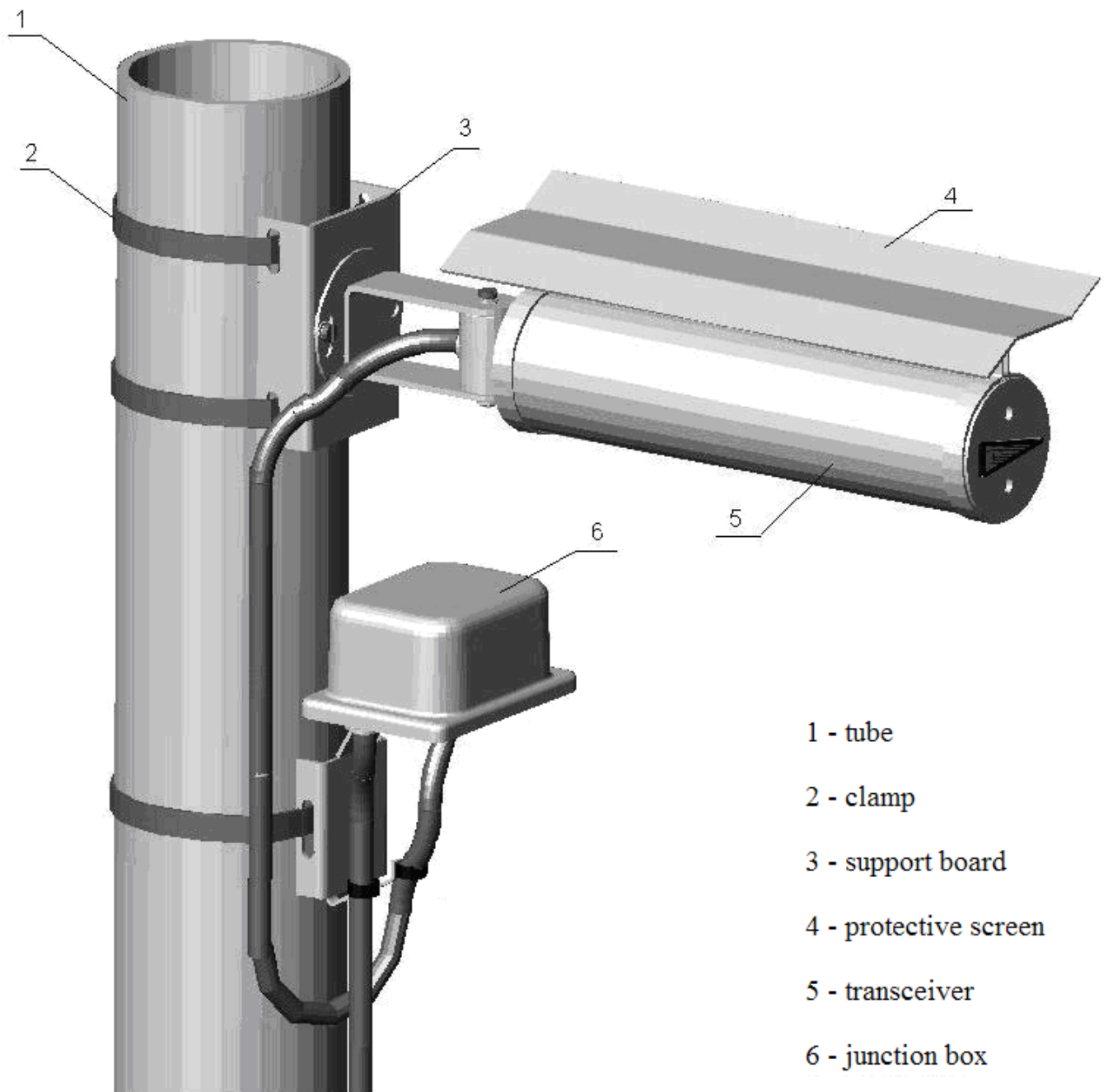

Picture 1.2 – detector’s design.

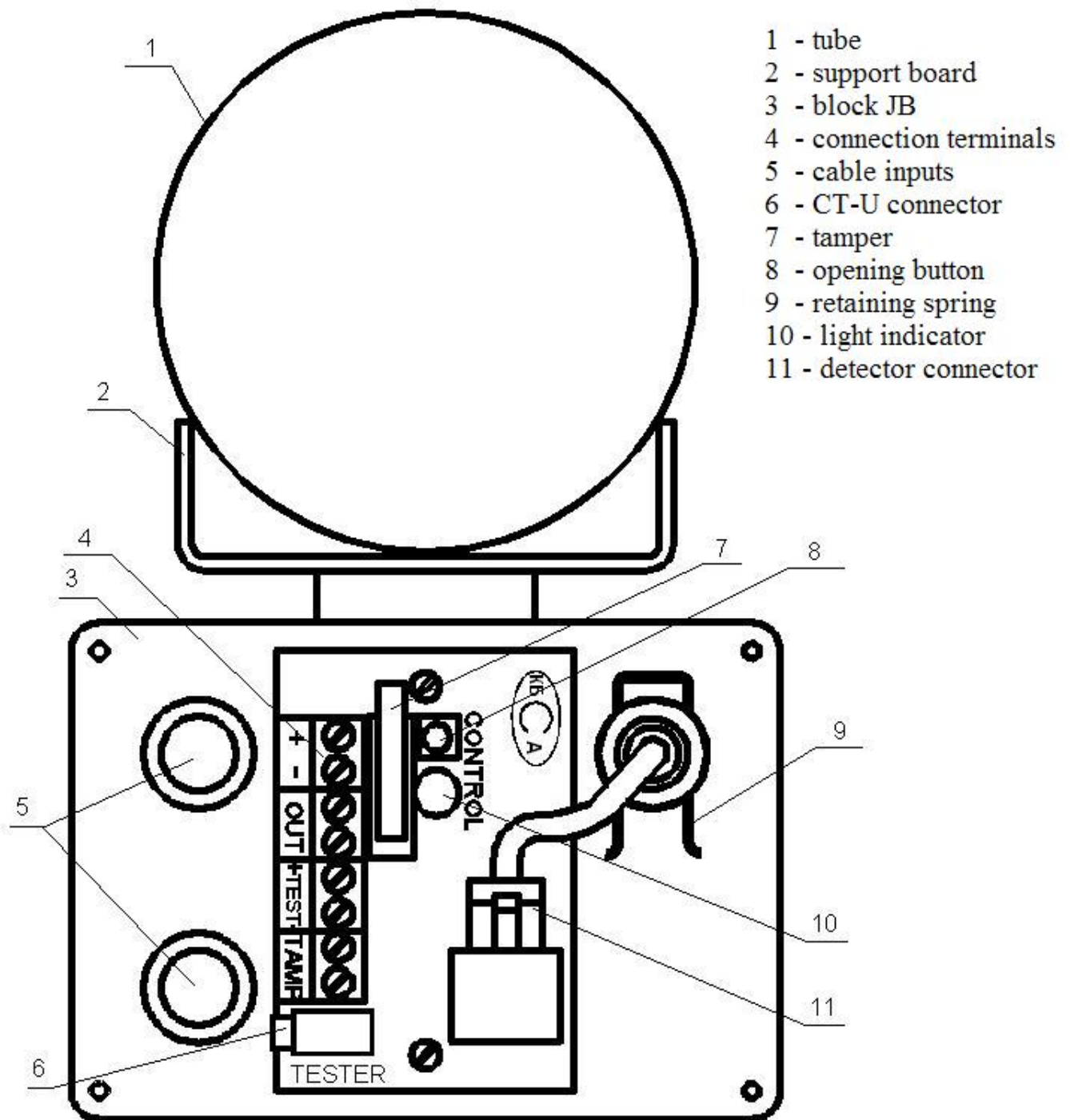

Picture 1.3 – control and commutation devices.

## 1.5 Marking

1.5.1 Detector's parts marking contains:

- The manufacture trade mark;
- The Detector's name;
- The serial number;
- Year and month of production;
- Quality department mark.

-

## 2.1 Activation and running-in

### 2.1.1 Safety precautions before activation

Observe the operational safety rules for electrical devices up to 1000 V while getting the detector ready for work and during its further usage.

The Detector radiation level conform to operational safety standards.

### 2.1.2 Requirements to the Detector installation

**Attention! The Detector stable operation depends on the following requirements implementation.**

2.1.2.1 The Detector should be installed on the walls or poles, without constant vibrations more than 1.5 m height (“blind” variant). If the Detector is used for horizontal areas protection (“square” variant), the recommended installation height is 1-1.2 m.

2.1.2.2 If the Detector is installed out-of-doors in the territory 50% more than DZ size, follow the given instructions:

- No bushes, branches, objects, shaking from the wind (gate wings, old fences), auto tents and so on;
- The grass height should be not more than 0.2 m;
- No transport, people and animals moving;
- There should be no objects in the DZ less than 2 m near the Detector in the place of installation where animals or birds can sit or move;
- no roofs drains near the Detector (up to 2 m forward and up to 0.25 m aside, powerful water sheets should be excluded in the whole territory of DZ.

2.1.2.3 Thoroughfares, forests, moving or shaking big metallic objects, constructional mechanisms, processing equipment should be removed from:

- From the Detector in the direction of radiation on the distance 75% more than set DZ size;
- From the DZ axis perpendicular to the radiation direction, on the distance equal to the DZ width in this distance from the Detector.

Notes:

1 There is no requirement to the territory out of radio-intransparent (metallic, ferroconcrete and so on).

2 If the Detector is used in the “square” variant, and with grass cover, to increase the noise resistance do not set the Detector range more than 30 m.

3 If the Detector is used as “blind”, rights-of-way zone can lessened in length, if the detector is mounted high.

### 2.1.2.4 To install the Detector inside, follow the given recommendations

- animals, birds, switched-on luminous tubes, vibrating and shaking objects (ventilator windows, doors, exhaust fans, etc. ) are not allowed in the protected room;
- do not direct the Detector to the exhaust fans, because the fan blades can revolve from moving air even if the fans are switched off;
- if the room has radio transparent (wood, glass, etc.) walls, floor, ceiling, Detector set DZ size should be a little bit less than the room size (determined by experience during the Detector regulation). To exclude out of the room moving detection, it is recommended to direct the Detector to the dead main walls.

2.1.2.5 It is important that the signal reflecting from a moving intruder depends on the visibility aspect (the observed contour square). So the signal from a person down to the Detector is two – three times less than that from a person in front or aside the Detector, in this case the DZ square can be decreased a little bit, and the observed intruder moving value will increase.

2.1.2.6 The DZ form and sensitivity can be changed because of radio waves reflecting from large metallic surfaces, mind it during the installation. It is not recommended to direct the Detector to the large, plane metallic surfaces perpendicular to the DZ axis, and to the angles made of three surfaces of high reflecting materials (metal, ferroconcrete, and so on), placed normal-angle to each other. The Detector's sensitivity to vibrations and objects moving, against the reflecting surfaces background, increases.

**Attention! If the article 2.1.2 requirements are not followed, the Detector performance characteristics can become worse. In this case experience will show the possibility to use the Detector.**

### 2.1.3 The Detector mounting

2.1.3.1 The Detector installation should provide easy access to the control panel and the fastening parts.

We recommend placing the connecting cables under ground.

2.1.3.2 Fix the bracket on the wall with screws and dowels. The Detector's pointer direction on the cover should coincide with the demanded DZ axis.

2.1.3.3 Use the following recommendations to install the Detector on the pole:

- Use a metallic tube from 50 to 90 mm in diameter as a pole. If the ground is soft, install it on the foundation. The type and size of the foundation depend on the ground type and climate for the location, to exclude adjusting troubles during exploitation;

- The Detector can be fixed on the round base with the support board and two clamps included in IAK. The JB is fixed on the tube with a clamp included in IAK.

2.1.3.4 Connection.

To connect the transceiver to the JB, pass the cable through the hole in the JB base, fix the cable bushing with a spring plunger and connect the header. The object cable is placed into JB through the cable input. Dress the cable end and connect to the JB clamps.

Connect the Detector following table 2.1 data.

Table 2.1.

№	Terminal marking	Terminal application
1	+	Supply plus
2	—	Supply minus
3	<b>OUT</b>	Output circuit
4	<b>OUT</b>	Output circuit
5	<b>TAMPER</b>	JB opening sensor
6	<b>TAMPER</b>	JB opening sensor
7	<b>+TEST</b>	TEST circuit plus
8	<b>TEST—</b>	TEST minus (connected to the supply minus)

**Attention! Control of the circuits resistance and the connecting cables conductors insulation is carried out only after the Detector is switched off and is disconnected from the controlled circuits.**

#### 2.1.4 Approbation and regulation of the Detector operation

2.1.4.1 Switch on the Detector's power supply. Take off the JB cover and check the power supply value on the appropriate JB terminals. The power supply value can be checked by the universal control tester (PK-U) or any other measuring device suitable for this check. The measured value should be from 11 to 28 V taking into account the necessary useful storage.

2.1.4.2 After the power is on the Detector can be regulated. Open the JB cover and regulate the Detector with operating controls in the JB, using PK-U passport.

**Attention! Detector in the regulation modes forms a trouble report (output circuit is broken).**

#### 2.1.4.3 Application variant choice.

The certain application variant can be chosen by PK-U, connect PK-U to the JB for this and use the PK-U passport.

#### 2.1.4.4 The Detector regulation with operation controls in the JB

**Attention! The indication mode is changed to the Detector range choice mode , threshold choice mode and back to the indication mode by holding the control button for more than 3 sec. If the button is not used for more than 10 min. the Detector automatically will go to the indication mode.**

a) Change the Detector to the **Detector range choice mode**. Then the indicator will show range of 20 m by one short flash in 10 sec, 30 m – by two flashes, and 40 m – by three flashes. To change the range value – push the control button for 0.5 – 1 sec.

**Note – the indicated range values are approximate, the actual value can differ a little bit from the indicated one, that is the result of the factory adjustment error, of the determined detection threshold, of the ground surface influence and of the reflecting objects location in the DZ.**

b) Change the Detector to the **alarms indication mode**. To check the operation and to precise the DZ border lines – do control walk full-length round the perimeter to the DZ axis normal from both sides, begin moving out of the DZ limits. Check the alarm reports while crossing the DZ or moving in the DZ (depends on the application mode choice) by the light indicator, check absence of an alarm report and signal “interference” presence by the indicator short flashes while the operator’s moving near the DZ border lines. If it is necessary, correct the Detector’s position and set range.

Note – here and further: operator’s weight, making the control walks during regulation, should be 50 – 80 kg, his height in bending position – from 0.8 to 1 m.

c) If there are operating mistakes (omissions, alarms while moving is out of the DZ limits) – change the detection threshold. If there is no PK-U, the threshold change is not recommended. To change the threshold – change the Detector to the **threshold choice mode**. Then the indicator goes to the constant light mode and by stopping one time in 10 sec. initiate before set threshold of 3 dB, by stopping two times – -0 dB, and by stopping three times – +3 dB. To change the threshold value – push the control button for 0.5 – 1 sec. repeat the Detector operation check after the threshold is changed (follow article 2.1.4.4 b).

#### 2.1.4.5 The detector regulation with PK-U

PK-U can choose the range value in 2 m increments with diapason from 10 to 28 m, and in 4 m with diapason from 28 to 40 m. the Detector range setting is described in PK-U passport.

**Note – the displayed range values are approximate, the actual value can differ a little bit from the indicated one, that is the result of the factory adjustment error, of the determined detection threshold, of the ground surface influence and of the reflecting objects location in the DZ.**

#### 2.1.4.6 The detection thresholds regulation

a) PK-U can choose the thresholds value from a wider diapason (from -6 to +6 dB) and accurate within 1 dB. To make the process easier, PK-U has a linear scale showing the chosen threshold and current signal values, and also alarms audio indicator.

b) The threshold setting consists of its value determination, which is the operator overcome during every control crossing the territory. Cross the DZ full-length to the axis line normal of the protected area at a distance equal to half of set range, and check alarm reports forming with the light indicator in the alarms indicating mode. Use PK-U to control the maximal value of the displayed signal, it should be from 4 to 8 dB (the signal is displayed relatively to the set threshold). If the signal differs from the mentioned value, regulate the threshold once more.

**Attention! The displayed signal value check during control crossing is obligatory after every threshold change.**

Note – here and further: operator’s weight, making the control walks during regulation, should be 50 – 80 kg, his height in bending position – from 0.8 to 1 m.

c) use control crossing along the territory perimeter to precise the DZ border lines, moving to the DZ axis normal from the both sides, begin moving out of the DZ lines. Check absence of alarm reports and signals “interference” (!! ) while moving near the DZ borders. If it is necessary, correct the Detector position and its range.

**Note – to make the control process easier, PK-U has an audio alarm indicator.**

2.1.4.7 Put the JB cover on its place and check the Detector operation, control the alarm transmission to the control unit at the RC signal (if this function is used), has given to the “+TEST” output voltage of 5-30 V, or during check DZ crossing. The Detector should form an alarm report in this case. During the Detector exploitation, it is recommended, to carry out RC every 8 hours.

**Note – set the minimum of the range needed and maximum of the threshold value during the regulation. Do not use lessening of the threshold to increase the DZ size, this leads to noise-resistance worsening.**

2.1.4.8 If PK-U displays signal “interference” without an operator in the DZ, it is necessary to check the protected territory compliance with the article 2.1.2 requirements, define the interference source and remove mismatches. If the mismatches can not be removed, follow the given instructions:

- Change the installation place or radiation direction;
- Lessen the Detector range;
- Increase the threshold value.

The acceptability of such actions is determined by the service department on the base of control crossings results.

If the interference is a result of “getting noticed” by near placed radio wave detectors, working on the same frequency, change the Detector place of installation or the influencing detector’s blocks, to lessen the effect.

It is important to remember that the interference from shaking objects and greenery can be absent in windless weather and appear with wind, during noise-resistance check.

2.1.4.9 Carry out an operation test day-and-night during not less than 3 days with all alarms registration and their analysis. During this, check the Detector operation by DZ control crossing not less than two times per day-and-night.

If there are false alarms or missing during control crossings, remove the cause using paragraph 2.2.

## 2.2 Operating

List of possible faults and troubleshooting are given in Table 2.2.

Table 2.2.

Trouble	Possible reasons for trouble	Troubleshooting
1 Detections are registered in the alarm circuit «OUT», there is no indication.	There is no supply voltage or it is too low.	Check the supply voltage. If it is below normal or absent, check power supply circuits and power supply unit.
	The Detector is defective.	Change the Detector.
2 Detections are registered in the alarm circuit «OUT», the indication fits the standard.	«OUT» circuit is defective.	Switch the «OUT» circuit from the control unit and check its integrity by “wire identification” with closed contacts of OUT. Check the the control unit final element installation correctness.
	The Detector is defective.	Change the Detector.
3 alarms are constantly registered in «TAMPER» circuit.	«TAMPER» circuit is defective.	Check «TAMPER» circuit integrity by “wire identification”. Check the the control unit final element installation correctness.
	The junction box cover is installed improperly.	Check the correctness of the covers installation.
4 Detections are constantly registered in «OUT» circuit, alarm is constantly displayed, PK-U displays message «U=LOW».	The supply voltage is below normal.	Check the supply voltage of the switched-on Detector, check supply circuits and PSU.
5 Detections are constantly registered in «OUT» circuit, alarm is constantly displayed, PK-U displays message «Fu».	The detector is defective.	Change the detector.

Table 2.2

Trouble	The possible reasons	Troubleshooting
6 the Detector does not form alarms reports while the operator's moving in the DZ	The service conditions do not meet the manual requirements.	Check if the service conditions agree with article 2.1.2 requirements.
	The Detector improper regulation.	Check the regulation conformity to the article 2.1.4.
	The Detector is defective.	Change the Detector.
7 Frequent false alarms	The service conditions do not meet the manual requirements.	Check if the service conditions agree with article 2.1.2 requirements.
	The Detector improper regulation.	Check the regulation conformity to the article 2.1.4.
	The power supply instability or the supply voltage pulse level overshoot, given in article 1.1.8.	Check the contacts reliability. Check the power supply unit by the Detector test operation with knowingly good supply unit.
	RC circuit is defective.	To shoot the trouble in the RC circuit – disconnect the RC circuit from the Detector, and carry out the Detector test operation without RC mode usage.
	«OUT» or «TAMPER» circuits are defective.	Short the output circuits with short-circuiter and carry out the test operation. False alarms registered in the control unit, in this case, are signs of «OUT» («TAMPER»), or the control unit defect.
The Detector is defective.	Change the Detector.	

## Notes

- 1 the Detector trouble can be find out by its replacement to the knowingly good one with its further test exploitation.
- 2 After all troubles are corrected, it is necessary to regulate the Detector using article 2.1.4 instructions.

### **3 Maintenance**

Maintenance consists of:

- The location conditions check in the right of way zone;
- The Detector external examination;
- Alarm reporting check.

Maintenance should be done monthly. In case of natural disasters influence (heavy snow, storms, heavy showers and so on), and in case of the greenery fast growing, it is recommended to carry out an unplanned place check.

It is also recommended to check the Detector's operation using article 2.1.4 not less than two times per year (during the seasons change period) and if some defects in operation are found.

Use an external examination to check the place conformity to article 2.1.2 requirements. Cut tree branches and bushes, mow the grass, and clean the territory from foreign objects, if necessary.

In winter time, change the blocks installation height and clean the place from snow, if necessary.

Check the Detector blocks fixing. If they are dirty, clean their surface.

Carry out test crossing in the DZ and test the Detector operation, by checking alarms coming to the the control unit.

Note – electrical connections check should be carried out in the general scheduled work limits of the intruder alarm system.

### **4. Storage, transportation and utilization**

Detectors should be stored packaged in storehouses with temperature range from 5°C to 30°C and air humidity of 85%.

Corrosive mediums influence during storage is not allowed.

The packaged detectors can be shipped by any transport type (by air – in pressurized modules) under condition of covered goods vans, holds or covered car bodies. Put the cases correctly, to exclude their moving or falling down by push or blow.

The Detector does not contain any precious, rare-earth and toxic materials. Utilize the Detector when its life time is over.

### **5. Acceptance certificate**

The sensor "Forteza M-40 ", № \_\_\_\_\_ meets performance specifications of this user manual document and it is considered as operable.

Date of issue \_\_\_\_\_ 201 .

Quality department

### **6. Manufacturer's Guarantees**

The manufacturer guarantees the conformity of the sensor specifications to requirements of this user manual if a user meets the service conditions and operating rules

specified by this user manual .Warranty period is 18 months since the date of sale by the manufacturer.

Guarantees do not cover the sensors:

- with broken guarantee stamps;
- with mechanical failures,
- and also those which are out of order because of natural disasters (lightning, fire and flood).

Mean lifetime is 8 years.

**For warranty and post-warranty service you can contact:**

**European Office:**

JCS "Forteza"

M.Mazvido av.9A-18

92136 Klaipeda

Lithuania

Phone+370 46 411353

Fax+370 46 412231

E-mail forteza@forteza.com

**Visit the site [www.FORTEZA.com](http://www.FORTEZA.com) for more information about additional Service Centers**