



**TRIBOELECTRIC GUARD ALARM
FOR PERIMETER AREAS
“FORTEZA TRIBO-M”**

Operation manual

Table of contents

1.	General information	4
1.1.	Purpose.....	4
1.2.	Operating conditions	4
1.3.	Technical characteristics.....	6
1.4.	Standard equipment.....	6
2.	DESIGN AND PRINCIPLE OF OPERATION	7
2.1.	Principle of Operation	7
2.1.1.	Sensor	7
2.1.2.	Signal-Processing Unit	7
2.1.3.	Adapter and Coupling.....	7
2.1.4.	Terminal Unit.....	7
3.	APPLICATION	8
3.1.	Versions of Fence Equipping	8
3.1.1.	Flexible Fence (Fig. 1)	8
3.1.2.	Wire-Netting Fence (Fig. 1a).....	8
3.1.3.	"Rabitsa" Wire-Netting Fence (Figs 1b and 1c)	8
3.1.4.	Barbed-Wire Fence (Fig. 1d).....	9
3.1.5.	Fence Made of Flat (Round) Reinforced Barbed Tape "AKЛ" (Fig. 1e)	9
3.1.6.	Rigid (Continuous) Fences (Fig. 2)	9
3.1.7.	Gate (Wicket) (Fig. 3).....	9
4.	Serviceability check	10
4.1.	Safety Precautions.....	10
4.2.	Serviceability Check.....	10
5.	Installation and preparation for use.....	11
5.1.	General	11
5.2.	SPU Installation.....	11
5.3.	Sensor Laying	12
5.4.	Splicing the Ends of the Tribocable and Connecting Cable	12
5.5.	Cables Termination in Adapter (Fig. 8).....	13
5.5.1.	To terminate the cables in the adapter, proceed as follows (Fig. 8a):.....	13
5.5.2.	To terminate the cables in the extended adapter in equipping gates and wickets (Fig. 8b), proceed according to Item 5.5.1 but be sure first to slip a required-length spiral wrap hose over cable PK. Then slip a seal over the spiral wrap hose end. Completing the cable termination be sure to put the spiral wrap hose end together with the seal into the case and tighten it with the third additional clamp.	13

5.6.	Cables Termination in Coupling.....	14
5.7.	Cable Termination in Terminal Unit (Fig. 9)	14
5.8.	Installation of Adapter and Coupling.....	14
5.9.	Terminal Unit Installation.....	14
6.	Controls	15
7.	Maintenance.....	16
7.1.	In maintenance be sure to observe the safety precautions specified in Section 4.....	16
7.2.	Types of maintenance services:.....	16
7.3.	For the scope of maintenance services, refer to Table 7.1.	16
8.	Storage and transportation	18
8.1.	When packed in Manufacturer's shipping boxes, guard alarms may be carried by any closed transport means (boxcars, covered trucks, pressurized heated cargo bays, holds, etc) including:.....	18
8.2.	Guard alarms in Manufacturer's transit packing should be stored in heated and ventilated storehouses with air conditioning located in any macroclimatic areas at an ambient temperature from +5°C to +40°C and relative air humidity up to 80% at 25°C.....	18
8.3.	The storehouse rooms should be free of dust and vapour of corroding agents.....	18
8.4.	Guard alarms may be transported at an ambient temperature from minus 40°C to +50°C and relative air humidity up to 100 % at 25°C. In transportation, be sure to protect them against direct exposure to precipitation and dust.	18
8.5.	Guard alarms in standard packing are stored one year, maximum. On the expiry of this period open the packing, inspect the guard alarm visually, remove revealed defects and pack the guard alarm in standard packing.....	18
9.	Repair and utilization.....	19
9.1.	All types of the signal-processing unit repair are to be performed by the Manufacturer.....	19
9.2.	Utilization of the signal-processing units that are not repairable is to be performed at enterprise JSC "Forteza".....	19
10.	Metrological support.....	20
10.1.	To ensure the check of the parameters specified in the present Operation Manual use should be made of the following calibrated measuring instruments:.....	20
	Contacts.....	21

1. General information

The operation manual contains information about the construction, technical features, operation and application of the **"Forteza Tribo-M"** security detector system. The manual also contains information, necessary for the proper installation and use of the device.

1.1. Purpose

"Forteza Tribo-M" is single-position triboelectric, passive and unmasked guard alarm system with surface detection zone, which is designed for extended perimeter areas and is used as a stationary unit.

The guard alarm system for perimeter fences is meant to generate alarm signals on the local deformation of the fence and the sensor fastened to it in unauthorized penetration by getting over the fence, no facilities being used, and as a result of damage to the fence, the sensor, and its fasteners.

The guard alarm system ensures the monitoring of the sensor integrity (the cable of triboelectric effect), the connecting cable being checked as well. On their damage (short-circuit or broken cable) the guard alarm system generates an alarm signal on the fault.

1.2. Operating conditions

The guard alarm system is intended for continuous round-the-clock operation. Its performance is maintained within the set normal values. The guard alarm does not generate the false "Alarm" signals on and after exposure to the outdoor environmental factors (OEF) given in Table 1.1.

Table 1.1

OEF	Description	Value
Acoustic noise	<i>Is not regulated</i>	
Elevated ambient temperature	Elevated operating temperature	+ 50 °C
Low ambient temperature	Low operating temperature	- 40 °C
Elevated humidity	Up to 98% at a temperature of +35 °C <i>Is not regulated with a signal-processing unit (SPU) installed in the metal alarm cabinet</i>	
Low humidity	<i>Is not regulated</i>	
Rain	<i>Is not regulated</i>	
Hoar-frost and ice-crusts on ground	Thickness (at wind speed)	2 mm (10 m/s)
Dew	<i>Is not regulated</i>	
Blanket of snow	<i>Is not regulated</i>	
Fog	Of any intensity	

Table 1.1 continued

OEF	Description	Value
Saline (sea) fog	Of any intensity	
Dust (sand)	Particles circulation speed	10 m/s
	Dust (sand) flow density	5 kg/m ² /s
Ultra-violet solar radiation	<i>Is not regulated</i>	
Wind	Mean wind speed	20 m/s
	Maximum wind speed value	30 m/s
Blizzards and sand-storms	Of any intensity	
Ground	Maximum sub grade slope for the fence	30 deg.
	Terrain irregularities along the fence axis	± 0,30
Herbage	<i>Is not regulated</i>	
Flood	For fence - depth	0.3 m
One-man movement, movement of several people (from 3 to 5 men) and big animals	Distance to the guarded zone	0.5 m
Driving of wheeled, full-track and electric-battery vehicles	Distance to the guarded zone	1.5 m
Railway freight and passenger transport	Distance to the guarded zone	15 m
Power lines (up to 500kV)	Distance to the guarded zone	5 m
Exposure to the radar electromagnetic field	Is not regulated (with a signal-processing unit installed in the metal alarm cabinet)	
Exposure to the ultra-short pulses of the electromagnetic field	Is not regulated (with a signal-processing unit installed in the metal alarm cabinet)	
Exposure to the momentum neutron flux	<i>Is not regulated</i>	
Influence of birds and small animals over the fence components: - birds - small animals	Weight	1 (5) kg up to 20 kg

1.3. Technical characteristics

- The guard alarm is energized from an uninterrupted DC power source with supply voltages from 9 to 36 V;
- With voltage drop below 5 V the guard alarm goes into the "Alarm" mod;
- Minimal length of the sensor to be connected (tribocable) comes to 1.2 m.
- Maximal length of the tribocable to be connected does not exceed 1000 m. (4 zones each 250 m);
- Maximal area of detection zone (enclosed area) depends on the fence type and the way of the sensor laying.

1.4. Standard equipment

The following equipment is included in the guard alarm delivery set:

- signal-processing unit;
- adapter;
- terminal unit;
- USB/RS485 cable
- Software

2. DESIGN AND PRINCIPLE OF OPERATION

2.1. Principle of Operation

The basis for the guard alarm operation is generation of electrical signals in the sensor and at its stress centers (points of the sensor rigid fastening to the fence) under mechanical action on the fence components and their subsequent detection by the signal-processing unit.

2.1.1. Sensor

The sensor mounted on the fence is meant for electrical signal generation under unauthorized mechanical actions on the fence.

It is a good practice to use tribocable as a sensor.

The sensor length depends on the guarded zone length, the fence height, number of supports, and the selected way of the sensor mounting on the fence.

2.1.2. Signal-Processing Unit

The signal-processing unit (SPU) is used for the sensor signals detection and the alarm signal generation.

SPU is designed in the metal case. Located inside the case is an electronic board arranged around which are in-circuit elements of the signal-processing unit, RS485 connection, terminals for the external circuits connection, and the guard alarm controls.

Provided on the SPU case are fasteners meant for its installation.

2.1.3. Adapter and Coupling

The adapter is meant for connecting the sensor together with its connecting cable to the signal processing unit and for the connection point shielding and sealing.

In equipping gates and wickets use should be made of an extended adapter permitting to fix a spiral wrap hose for the connecting cable protection.

The coupling is used when needed to connect two separate portions of the sensor and for the connection point shielding and sealing.

The coupling is equipped with nylon ties needed for its fastening to the fence.

2.1.4. Terminal Unit

The terminal unit provides a continuous monitoring of the sensor and the SPU connecting cable integrity. It is also meant for the sensor end point shielding and sealing.

3. APPLICATION

To ensure the required detectability (unauthorized actions detection), high noise immunity (actually an utter absence of false responses) and specified sabotage resistance

THE FOLLOWING SHOULD BE PROVIDED:

- proper fence mounting (flexible fences should be stretched uniformly with specified tension force);
- combination of different-type fences and of tribocable laying and fastening schemes;
- fence uniformity, i.e. the fence should be made of the same material as different-material sections generate signals of different strength when subjected to an unauthorized action;
- tribocable proper installation and tightness;
- SPU sensitivity setting with specified detectability.

3.1. Versions of Fence Equipping

Possible are the following versions of the guard alarm installation:

- flexible fence made of reinforced barbed tape , wire netting, wire netting "Rabitsa", barbed wire, etc. (Fig.1);
- rigid (continuous) fence made of metal elements (forged and welded gratings, solid metal plates, corrugated plates, etc.), concrete, bricks, wood, etc. (Fig.2);
- gates, wickets, etc. (Fig.3).

3.1.1. Flexible Fence (Fig. 1)

Flexible fence is actually a fence made of metal wire netting according, barbed wire, wire of rust-resistant steel, bimetallic wire, reinforced barbed tape, etc.

The sensor is mounted directly on the fence flexible elements. The supports enabling a violator to get over the fence without touching its flexible elements being available, the sensor is mounted on the supports as well.

The "Alarm" signal is generated on the flexible fence under local deformation of the fence and the sensor fastened to it in case of unauthorized penetration by getting over the fence, no facilities being used, and as a result of damage to the fence, the sensor, and its fasteners.

To obtain the required noise immunity, be sure to limit the flexible fence mobility under wind as much as possible.

3.1.2. Wire-Netting Fence (Fig. 1a)

The wire-netting fence should meet the following requirements: make sure the netting is stretched uniformly between the fence supports in a horizontal plane with a force of 100 kg, minimum.

3.1.3. "Rabitsa" Wire-Netting Fence (Figs 1b and 1c)

The "Rabitsa" wire-netting fence should meet the following requirements:

- make sure the netting is stretched uniformly between the fence supports in a horizontal plane and fastened to the upper and lower wire ropes (Fig. 1b);
- a frame made of angle sections being used, make sure the netting is stretched uniformly and fastened to the all sides of the frame. In addition be sure to lay the sensor along the upper angle section of the frame and the fence supports (Fig. 1c).

3.1.4. Barbed-Wire Fence (Fig. 1d)

The barbed-wire fence is actually barbed wire stretched in several level lines between rigid supports. Stretched diagonally is also barbed wire fastened to each level wire line, which, in its turn, should be rigidly fastened to each fence support.

The barbed-wire fence should meet the following requirements: make sure barbed wire is stretched in a horizontal plane with a force of 200 kg, minimum. 8

3.1.5. Fence Made of Flat (Round) Reinforced Barbed Tape “AKЛ” (Fig. 1e)

The “AKЛ” tape fence should meet the following requirements: make sure the reinforced barbed tape is fastened to the wire ropes stretched between the fence supports with a force of 200 kg, minimum, on two sides.

3.1.6. Rigid (Continuous) Fences (Fig. 2)

Rigid fence is a fence made of metal elements (forged and welded gratings, solid metal plates, corrugated plates, etc.), wooden materials, reinforced concrete panels, concrete blocks, brickwork or masonry.

The sensor is mounted directly on the rigid fence elements. The supports enabling a violator to get over the fence without touching its rigid elements being available, the sensor is mounted on the supports as well.

To equip rigid fence of forged and welded gratings be sure to lay the sensor according to the diagram with stress centers on every bar (**Fig. 2 a**);

To equip rigid fence of wooden materials, solid metal plates and corrugated plates, be sure to lay the sensor according to the diagram, stress centers being made with clamps (**Figs 2b and 2c**).

Note. The stiffener being available at the top of the fence, be sure to lay the sensor along this stiffener as well.

To equip rigid solid fence of reinforced concrete panels, concrete blocks, brickwork or masonry, be sure to lay the sensor along the fence upper crown under the visor made of deformable material, for example, plate (**Fig. 2d**).

An extra flexible fence being available over the rigid solid one, be sure to lay the sensor along the flexible fence (**Fig. 2e**).

3.1.7. Gate (Wicket) (Fig. 3)

The gate (wicket) is actually a frame made of metal angle sections or tubes, the inner space being filled with bars or netting welded to the frame. The inter-bar clearance should not exceed 0.15 m.

The aforesaid requirements cover gates (wickets) as well.

The fence and the gate being of the **same material**, just **one sensor** can be used.

If so the sensor is laid on supports between the fence and the gate through special stretch-out boxes, **extended** adapters and a spiral wrap hose.

Be sure to lay the sensor from one gate leaf to another in a metal bypass pipe buried at a depth of 0.3 m, minimum.

The fence and the gate being of different materials, be sure to equip them with separate guard alarms.

4. Serviceability check

4.1. Safety Precautions

Only a skilled electrician, at least of the fifth rate, familiar with the present Manual is entitled to perform the guard alarm installation, operation and maintenance.

Be sure to observe the instructions for the electric tools use and working at a height in the guard alarm installation and maintenance.

Make sure the measuring instruments switched into the AC circuit are reliably grounded.

4.2. Serviceability Check

The guard alarm is to be inspected for external defects on its receipt from the Manufacturer.

Check the guard alarm for serviceability in compliance with Table 4.1.

Table 4.1

Description and procedure of check	Technical requirements
Check of completeness	Correspondence with the certificate and contract
Check for appearance Visual inspection	Absence of mechanical damages and corrosion. Availability of intact Manufacturer seal on the cover of the SPU case

5. Installation and preparation for use

5.1. General

Be sure to observe all norms and regulations for assembling and wiring work in the guard alarm installation.

The guard alarm being powered from the remote power source, select the type of wire and the conductor cross-section so that the voltage across the SPU terminals is from 9 to 36 V with the output power supply voltage changing within permissible limits.

IMPORTANT. To ensure the guard alarm trouble-free operation provision should be made for the standby DC power supply

Use non-sensitive cable to connect the sensor to the signal-processing unit.

Make sure non-sensitive cable is hidden and the possibility of its damage is eliminated when laying the cable from the signal-processing unit to the sensor end.

5.2. SPU Installation

In equipping the perimeter fences it is a good practice to install the signal-processing unit in the metal splash-proof cabinet to improve the guard alarm sabotage resistance and to allow for the additional equipment location (an alarm button, a network controller of the data acquisition and processing system, etc). Be sure to locate the cabinet and the signal-processing unit in it so that the connecting cables of the sensor, alarm stub, remote-monitoring stub and power leads are conveniently connected and the possibility of SPU periodic inspection and adjustment is provided.

Prior to the SPU installation, do holes layout work for the SPU fastening and fasten it with screws and screw nails.

The following equipment is to be connected to the signal-processing unit:

- ground bus (uninsulated copper wire of cross-section 1.0 mm^2 , minimum);
- sensor connected by means of connecting cable;
- alarm stub;
- remote-monitoring stub;
- supply line.

CAUTION.

Be sure to ground the guard alarm only at one point - by a fastener on the SPU case. In mounting the connecting cable, sensor and terminal unit, be sure to eliminate the possibility of grounding at other points of electric circuit.

In connecting alarm and remote-monitoring stubs, MAKE SURE they are de-energized. Check the conductors' polarity in connecting the supply line.

5.3. Sensor Laying

Prior to laying, proceed as follows:

- check the sensor insulation resistance (make sure the insulation resistance between all the conductors and the braided shield is at least 1 MOhm);
- first, arrange the sensor along the fence inside without bights; make sure it is free of mechanical damages and the sensor ends are protected from moisture ingress.

To lay the sensor, proceed as follows:

- proceed according to the design documents;
- make sure the ambient temperature is not less than minus 10 °C;
- in laying the sensor along the fence make sure the radius of its bend is 120 mm, minimum;
- the stress centers should be made with steel galvanized wire at least 1.6 mm in diameter or with rigid steel clamps;

CAUTION. *The cable fastening should be rigid enough to prevent its ANY lengthwise movement relative to the attaching point and the fastener movement relative to the fence.*
To create "stress centers" at attaching points BE SURE to provide for the tribocable sheath visible deformation without its integrity breaking.

Sensor cuttings being used interconnect them with a coupling.

5.4. Splicing the Ends of the Tribocable and Connecting Cable

Splice the ends of the tribocable and connecting non-sensitive cable.

To prepare the tribocable, proceed:

- slip a seal over the tribocable;
- remove the external insulation of the tribocable for a distance of 35 to 40 mm;
- cut the braided shield off except for 9 to 11 mm left at the external insulation edge;
- cut the contact wire off except for 9 to 11 mm left at the external insulation edge;
- bend the braided shield with the contact wire towards the external insulation;
- cut the tape off for a distance of 2 to 3 mm from the external insulation edge;
- cut off all central conductors for a distance of 30 to 32 mm from the external insulation edge;
- skin all central conductors;
- cut the conductors off bringing their number to six and twist all the conductors together;
- apply plastic straps serving to the folded braided shield except for 35 to 40-mm wire end left uncovered;
- shape the twisting of central conductors in compliance. Be sure to get a total length of 28 mm;
- make sure the length of the six-conductor tail is 6 mm, minimum.

To prepare cable non-sensitive, proceed as follows:

- slip a seal for non-sensitive cable over the cable;
- slip an ebonite bush over the cable;
- remove the external insulation from non-sensitive cable for a distance of 42 to 44 mm;
- divide the braided shield into strands;
- apply the braided shield strands to the ebonite bush;
- apply tinned-wire serving except for 35 to 40-mm wire end left uncovered;
- remove the central conductor insulation except for 18 to 20 mm left at the external insulation edge;
- fold the skinned central conductor in two layers and twist it so that the length of the skinned end comes to 12 mm;
- shape the central conductor in compliance. Be sure to get a total length of 28 mm;
- make sure the tail length is 6 mm, minimum.

5.5. Cables Termination in Adapter (Fig. 8)

5.5.1. To terminate the cables in the adapter, proceed as follows (Fig. 8a):

- pull the spliced ends of the tribocable and non-sensitive cable through the braided shield and adapter case holes;
- connect the spliced ends of the tribocable and non-sensitive cable to the corresponding contacts of the terminal block. Be sure to insulate bare portions of the tribocable and non-sensitive cable central conductors from accidental contact with the braided shield;
- slip the braided shield over the cable connector and the bush so that the edges of the braided shield and the bush coincide. In so doing, make sure the tinned-wire leads are arranged through the centre of the braided shield contact;
- crimp the braided shield contacts together with the tinned wire. Make sure the diameter is not in excess of 16 mm;
- slip the adapter over the braided shield;
- put gaskets into the adapter case;
- tighten the screws of two clamps so that the adapter case fits tightly against the cables (make sure the locations of clamps and gaskets coincide).

To prevent moisture ingress into the adapter use should be made of neutral sealant applied at the points of the adapter case and gaskets contact.

5.5.2. To terminate the cables in the extended adapter in equipping gates and wickets (Fig. 8b), proceed according to Item 5.5.1 but be sure first to slip a required-length spiral wrap hose over cable PK. Then slip a seal over the spiral wrap hose end. Completing the cable termination be sure to put the spiral wrap hose end together with the seal into the case and tighten it with the third additional clamp.

Be sure to tighten **only non-sensitive cable seal**, not the spiral wrap hose one.

5.6. Cables Termination in Coupling

To terminate the cables in the coupling, proceed according to Item 5.5.1 except that the second cutting of the tribocable is connected to the terminal block instead of non-sensitive cable. To prevent moisture ingress into the coupling use should be made of neutral sealant.

5.7. Cable Termination in Terminal Unit (Fig. 9)

Splice the tribocable end in compliance with Item 5.4.

To terminate the tribocable in the terminal unit, proceed as follows:

- pull the spliced end of the tribocable through the holes of the braided shield and the terminal unit case;
- use the terminal block to connect the spliced end of the tribocable to the printed circuit board and tighten the fastening screws;
- be sure to insulate the bare portions of the tribocable central conductors from accidental contact with the braided shield;
- slip the braided shield over the cable connector and the bush so that the edges of the braided shield and the bush coincide. In so doing, make sure the tinned-wire leads are arranged through the center of the braided shield contact;
- crimp the braided shield contacts together with the tinned wire. Make sure the diameter is not in excess of 16 mm;
- slip the terminal unit case over the braided shield;
- put seal and a plug into the terminal unit case;
- tighten the clamp screws so that the terminal unit case fits tightly against the cable. Make sure the locations of clamps and gaskets coincide.
- To prevent moisture ingress into the terminal unit use should be made of neutral sealant.

5.8. Installation of Adapter and Coupling

The adapter should be installed on the fence at the tribocable and connecting cable joint. The coupling should be installed on the fence at the tribocable cuttings joint.

To ensure against moisture running down from the cable towards the coupling, be sure to install the coupling horizontally over the cable.

With all electrical connections completed according to the schematic diagram, use nylon ties being a part of the coupling delivery set to fastened it to the fence.

5.9. Terminal Unit Installation

To ensure against moisture running down from the cable towards the terminal unit, be sure to install the terminal unit horizontally over the tribocable.

With all electrical connections completed according to the connection diagram, use nylon ties being a part of the terminal unit delivery set to fastened it to the fence.

6. Controls

All controls and configurations can be done using PC program.

Connect SPU to PC via USB to RS485 connector (Provided in standard equipment package).

Install provided Software.

For detailed configuration see **Appendix 1**.

7. Maintenance

7.1. In maintenance be sure to observe the safety precautions specified in Section 4.

7.2. Types of maintenance services:

- Monthly maintenance No.1;
- Seasonal maintenance is performed in the guard alarm preparation for use at autumn-winter and spring-summer periods;
- Annual maintenance No.2.

7.3. For the scope of maintenance services, refer to Table 7.1.

Table 7.1

Type of maintenance	Operations performed	Procedure	Norms
1. Maintenance No 1 (monthly)	1.1. SPU visual inspection and cleaning without opening it	Clean the SPU surface of dust, dirt and moisture. Make sure the case is free of mechanical damages. Check the seal for availability	The SPU surface should be free of dust, moisture and pronounced mechanical damages. The seal should be intact
	1.2. SPU check for reliable grounding	Inspect the points of ground connection visually. Tighten the screws up	Screw joints should be tightened safely
	1.3. Visual inspection of the sensor, adapter, coupling, and terminal unit		The sensor, adapter, coupling, and terminal unit should be free of damages. The fastening to the fence should be intact
	1.4. Guard alarm check for serviceability with the remote monitoring function	Apply a 0.1 to 0.5-s supply voltage pulse to the «ДК» input of the signal-processing unit. With the test-receiving equipment at the using activity not permitting the use of the remote monitoring function, subject the fence components at its different portions to the check action with a force of 8 kg, minimum, for flexible fences and 20 kg, minimum, for rigid ones	In so doing the guard alarm should go into the "Alarm" mode and then again into the "Guard" one. The guard alarm should go into the "Alarm" mode and then again into the "Guard" one upon every check action

Table 7.1, continued

Type of maintenance	Operations performed	Procedure	Norms
2. Seasonal maintenance	2.1. Proceed to maintenance No. 1		
	2.2. Check for delectability	<p>Simulate an attempted penetration over the fence (mechanical action on the fence with a force of 8 kg, minimum, for flexible fences and 20 kg, minimum, for rigid ones).</p> <p>With no alarm signal, strive for the steady alarm signal generation under attempted penetration over the fence. To this end use the sensitivity controller to increase the guard alarm sensitivity</p>	The guard alarm should go into the "Alarm" mode and then again into the "Guard" one upon every check action
	2.3. Check for noise immunity	<p>Subject the fence to an action with a force of 4 kg, maximum, for flexible fences and 10 kg, maximum, for rigid ones.</p> <p>Less than 1-s fence stroke with a wooden stick (branch stroke simulation).</p> <p>The guard alarm being switched to the "Alarm" mode, use the sensitivity controller to reduce the guard alarm sensitivity and proceed according to Items.2.2 and 2.3</p>	The guard alarm should not go into the "Alarm" mode upon every check action
	2.4. Grounding resistance measurement	Use an ohmmeter to measure the grounding resistance	R_{GR} should not exceed 10 ohm
3. Maintenance No. 2 (annual)	3.1. Proceed according to Items 1.1 to 1.3 of the monthly maintenance		
	3.2. Check the external circuits and SPU terminal blocks for reliable connection	Remove the SPU cover. Make sure the wires are reliably connected to the terminal blocks. With loose attachment, tighten the screws of the terminals. Place the SPU cover into position and seal it	External circuit wires should be reliably connected to the terminal blocks in compliance with the connection diagram
	3.3. Proceed according to Item 1.4 of the monthly maintenance		
	3.4. Proceed according to Items 2.2 to 2.4 of the seasonal maintenance		

8. Storage and transportation

8.1. When packed in Manufacturer's shipping boxes, guard alarms may be carried by any closed transport means (boxcars, covered trucks, pressurized heated cargo bays, holds, etc) including:

- road transport running along the roads with unimproved pavement or without it with a speed up to 50 km an hour, while along some sections with a speed up to 20 km an hour, for a distance of 500 km provided the shipping boxes are rigidly secured on the truck bed;
- road transport running along the roads with improved pavement provided the shipping boxes are rigidly secured on the truck bed;
- air transport except for non-heated cargo bays; railway and water transport, distance unlimited, provided the shipping boxes are secured according to the regulations applied to the given transport means.

8.2. Guard alarms in Manufacturer's transit packing should be stored in heated and ventilated storehouses with air conditioning located in any macroclimatic areas at an ambient temperature from +5°C to +40°C and relative air humidity up to 80% at 25°C.

8.3. The storehouse rooms should be free of dust and vapour of corroding agents.

8.4. Guard alarms may be transported at an ambient temperature from minus 40°C to +50°C and relative air humidity up to 100 % at 25°C. In transportation, be sure to protect them against direct exposure to precipitation and dust.

8.5. Guard alarms in standard packing are stored **one year, maximum**. On the expiry of this period open the packing, inspect the guard alarm visually, remove revealed defects and pack the guard alarm in standard packing.

9. Repair and utilization

- 9.1. All types of the signal-processing unit repair are to be performed by the Manufacturer.
- 9.2. Utilization of the signal-processing units that are not repairable is to be performed at enterprise JSC "Forteza".

10. Metrological support

10.1. To ensure the check of the parameters specified in the present Operation Manual use should be made of the following calibrated measuring instruments:

- multimeter, accuracy class 2.5;
- megohmmeter, accuracy class 1.5;
- dynamometer, accuracy class 2.

Note. Use may be made of similar measuring instruments with accuracy class not less than the aforesaid ones.

Contacts

JSC "Forteza"

Tilzes str. 38
LT-91112, Klaipeda
Lithuania

Phone: +370 46 411353

Fax: +370 46 412231

forteza@forteza.com

www.forteza.com

- Fig.1 -
Flexible Fence Equipping

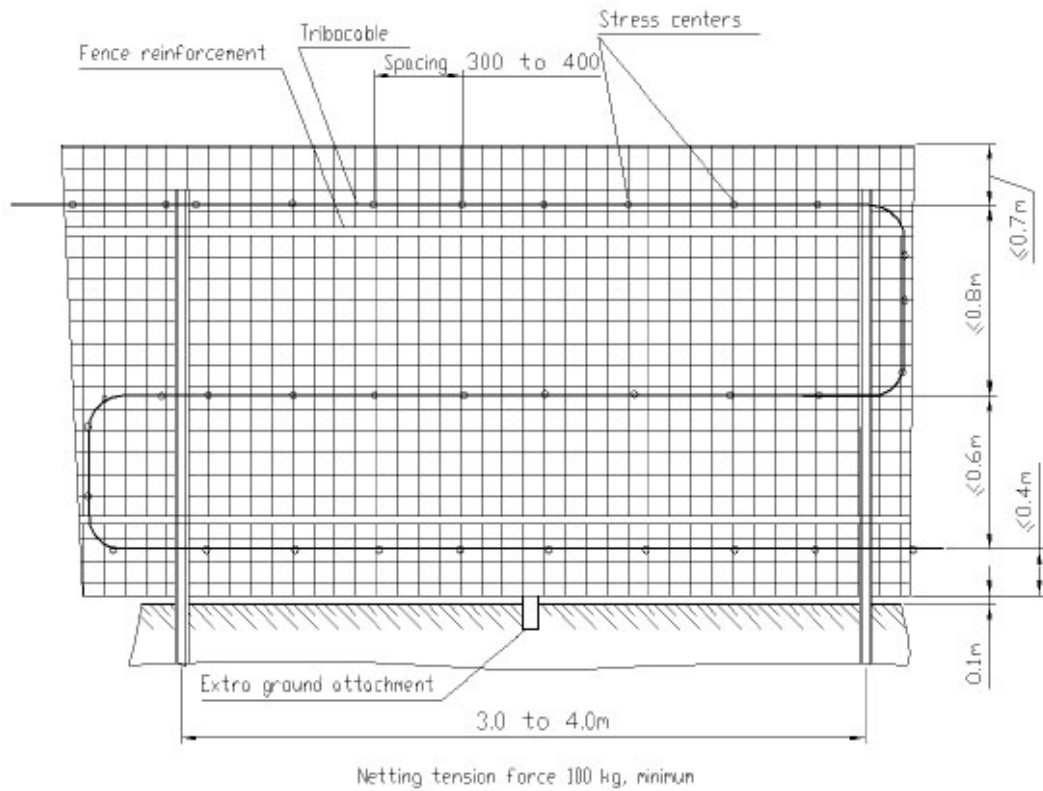

Fig.1a
ССЦП Wire-Netting Fence

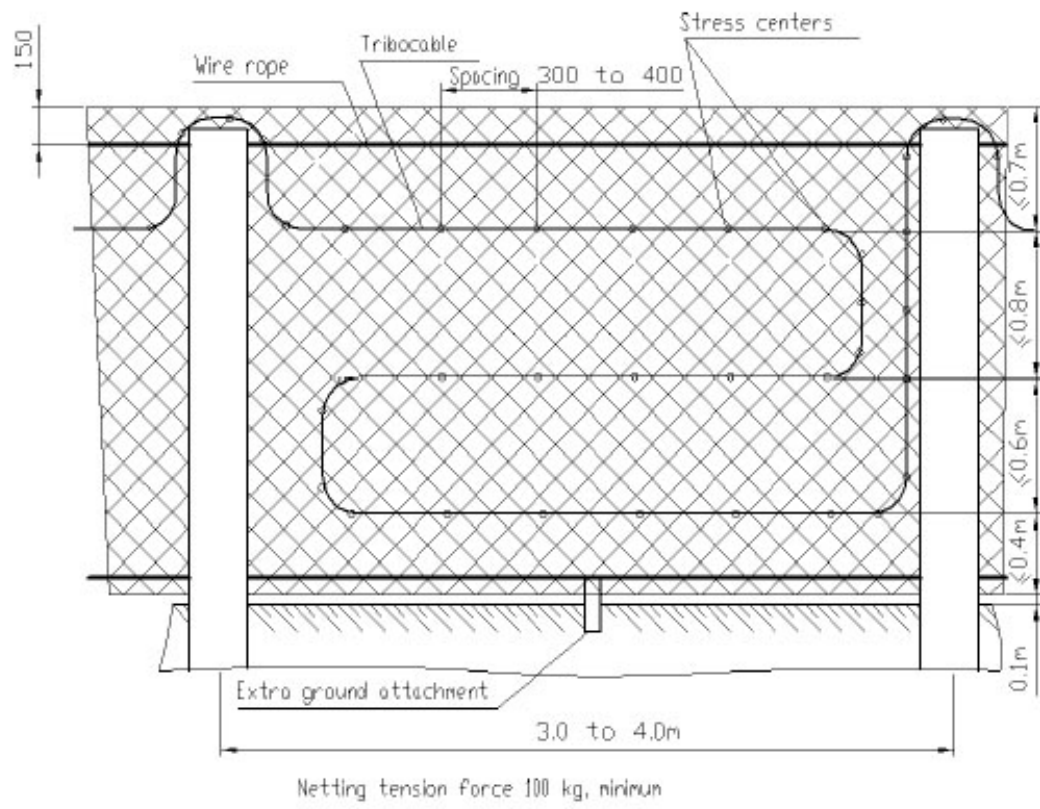

Fig.1b
"Rabitsa" Wire-Netting Fence

- Fig.1 -
Flexible Fence Equipping

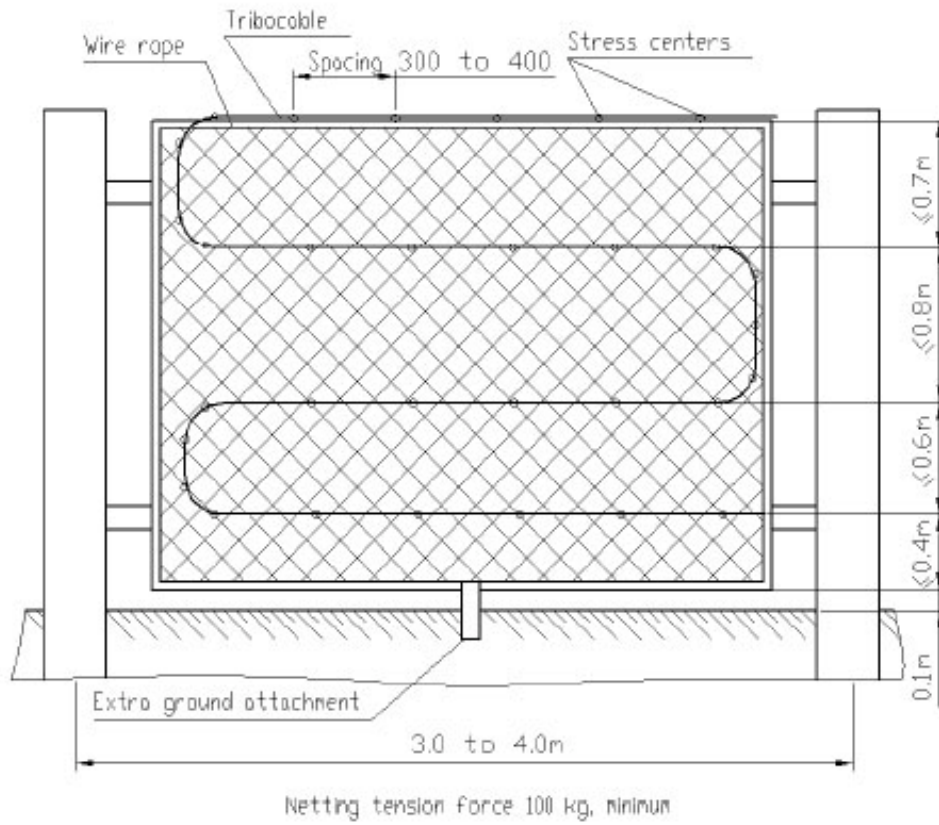
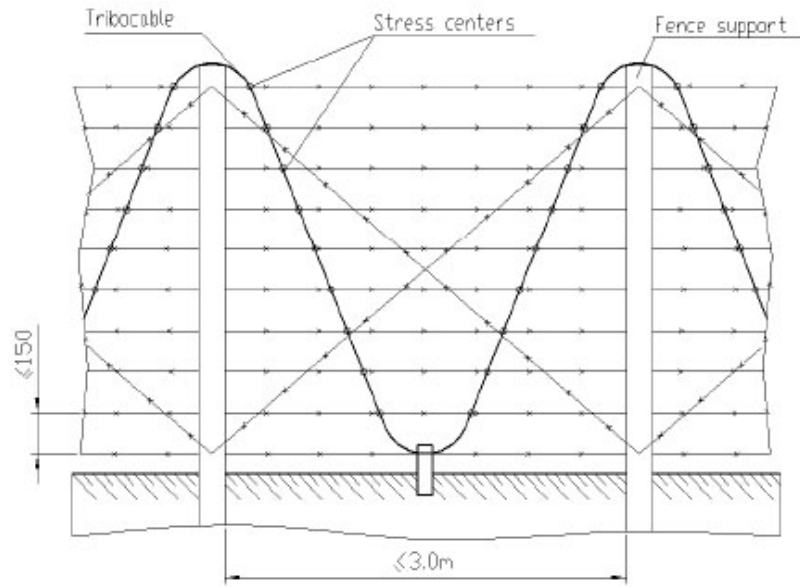

Fig.1c
"Rabitsa" Wire-Netting Fence



Wire tension force in a horizontal plane 200 kg, minimum

Fig. 1d
Barbed-Wire Fence

- Fig.1 -
Flexible Fence Equipping

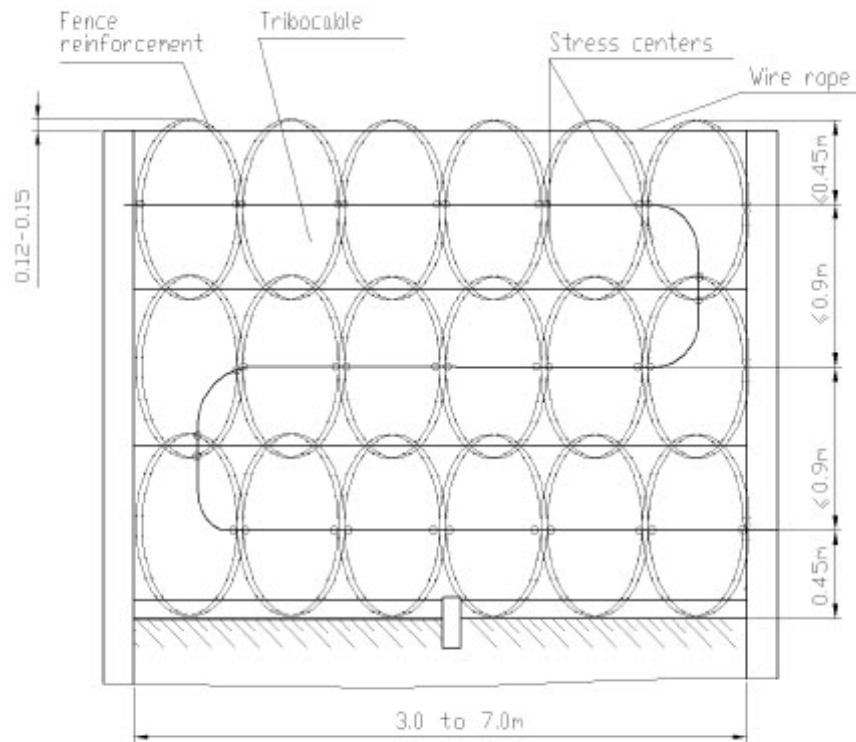

Wire rope tension force 200 kg, minimum

Fig.1e
Fence of Reinforced Barbed Tape (AK/A)

- Fig.2 -
Rigid (Continuous) Fence Equipping

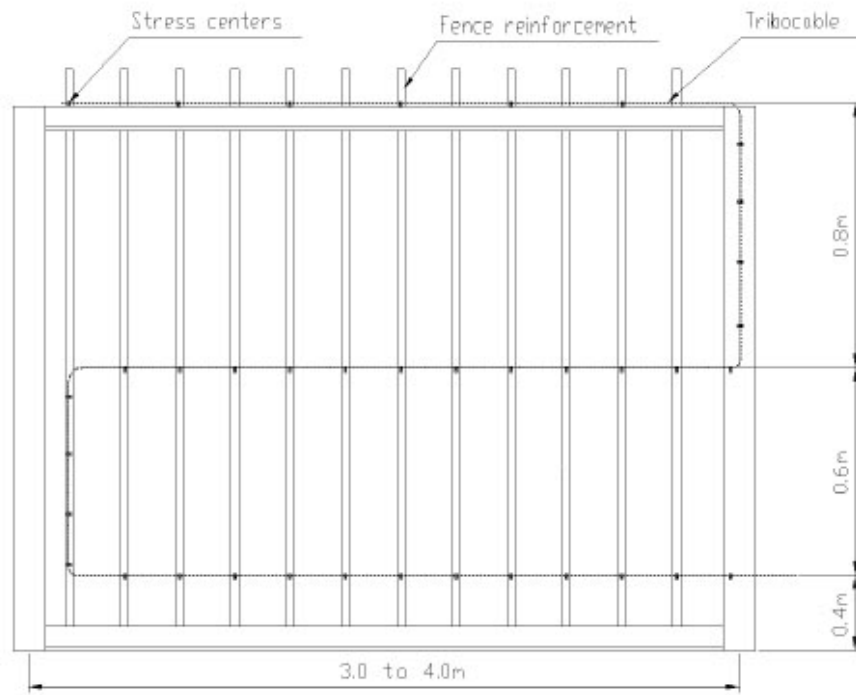

Fig. 2a
Fence of Welded (Forged) Gratings

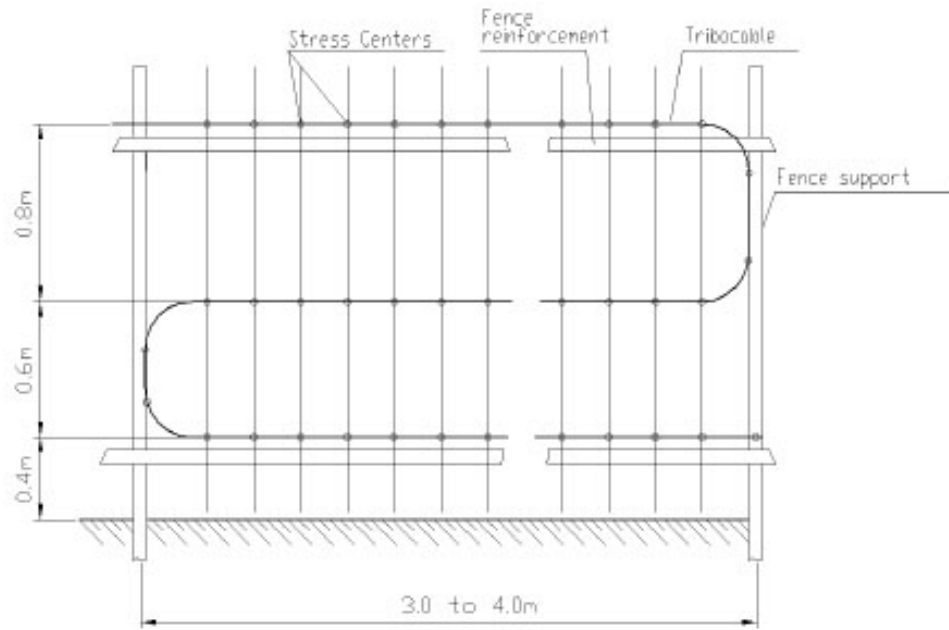

Fig.2a, continued

Fence of Welded (Forged) Gratings

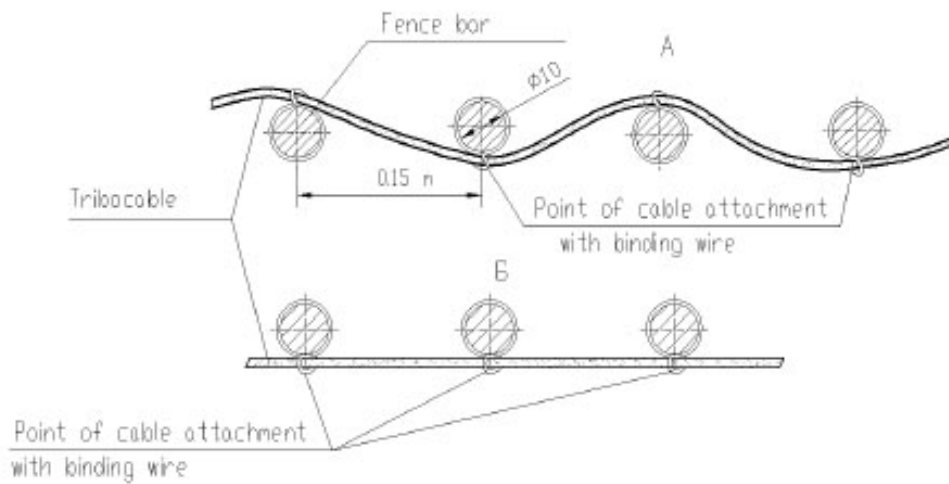

Fig.2a, continued

Fence of Welded (Forged) Gratings

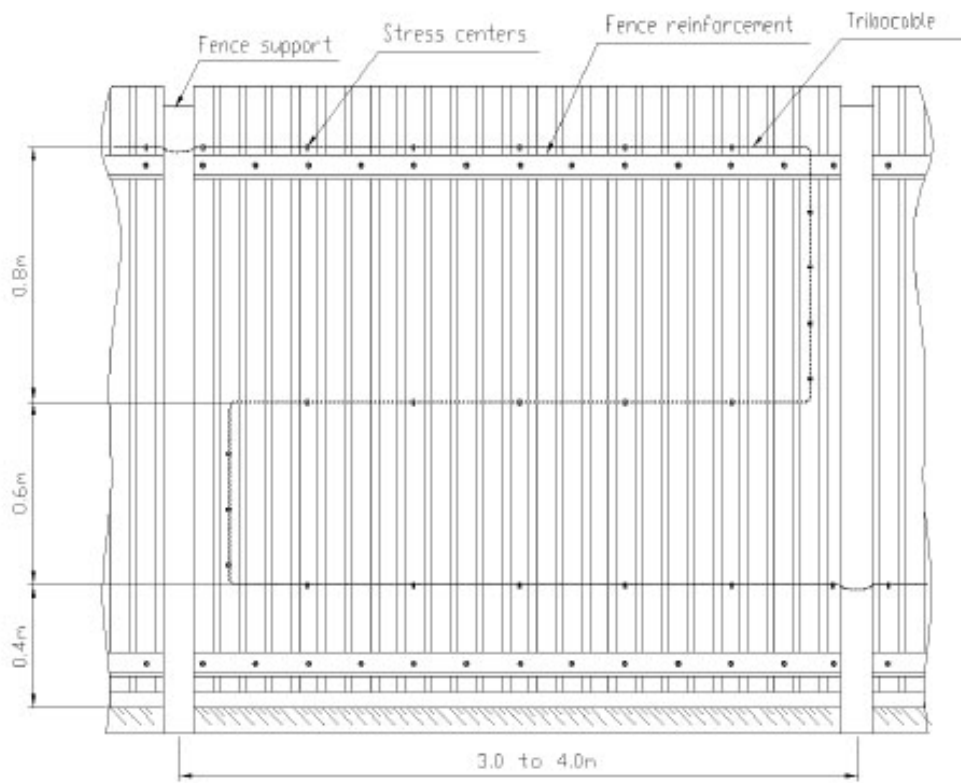

Fig. 2b
Fence of Solid Metal Plates

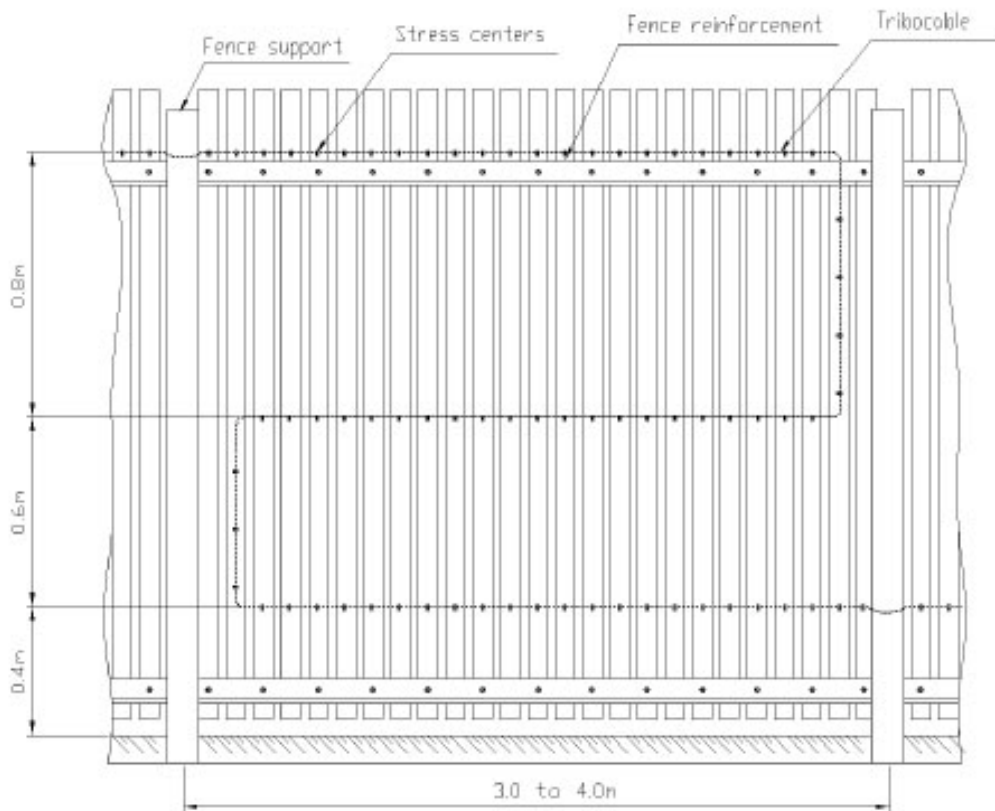
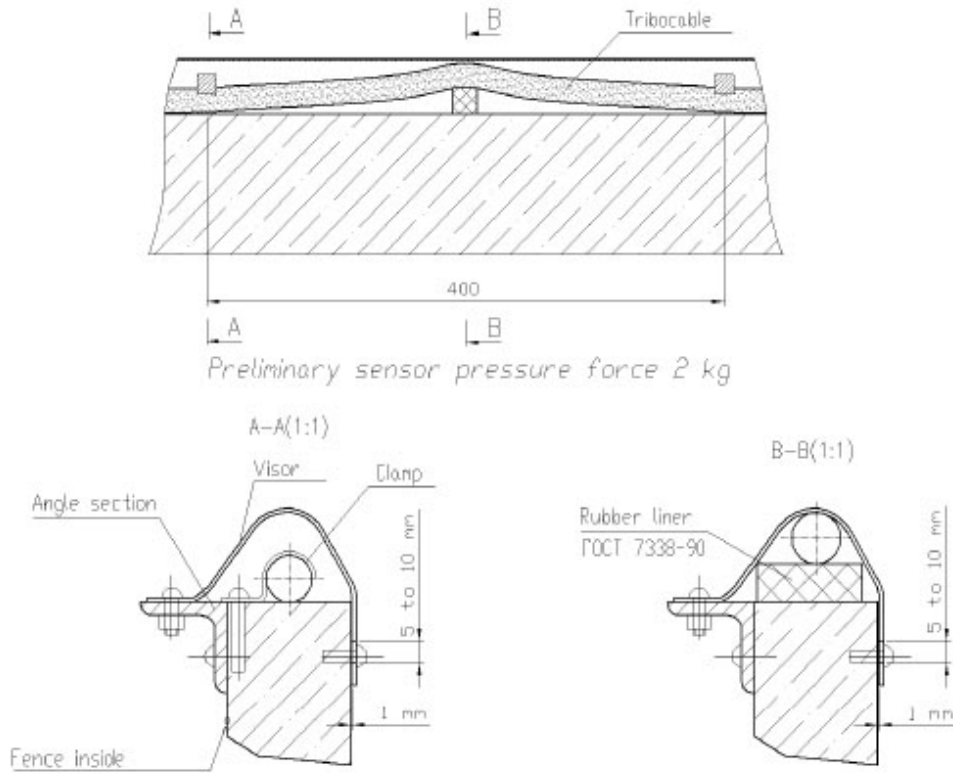

Fig. 2c
Wooden-Material Fence



Preliminary sensor pressure force 2 kg

Fig.2d
Fence with Visor

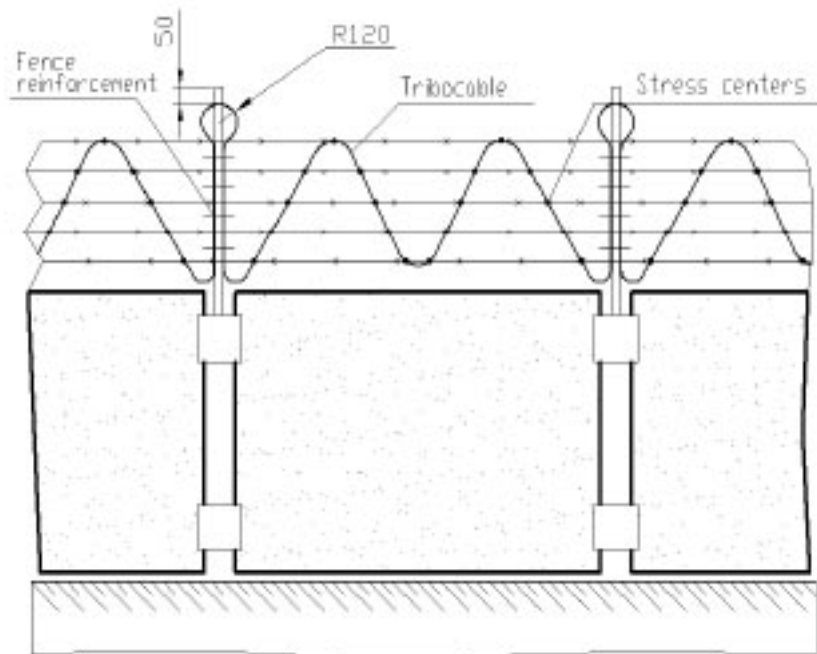

Fig. 2e
Extra Barbed-Wire Fence

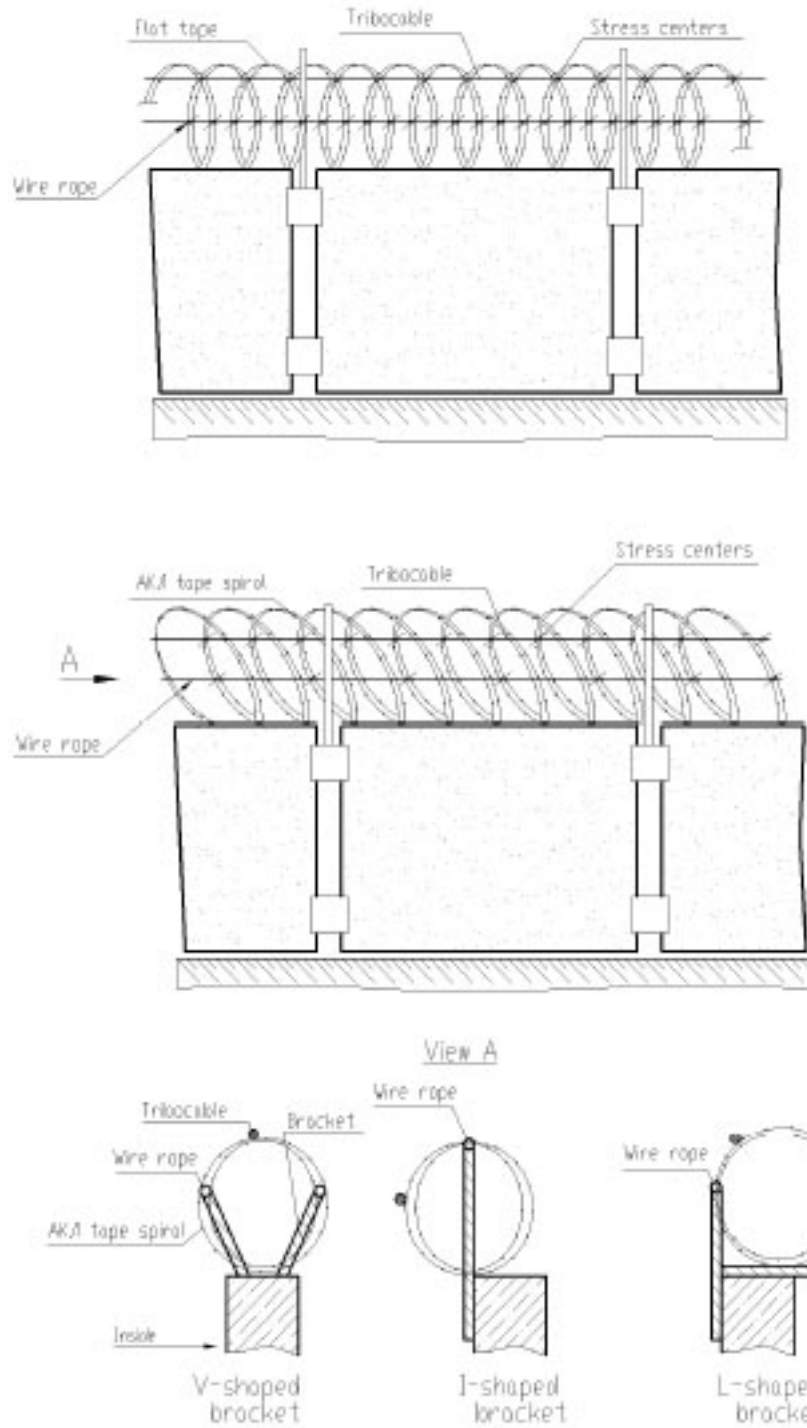

Fig.2e, continued
Extra Fence of Spiral or Flat Barbed Tape

- Fig.3 -
Gate (Wicket) Equipping

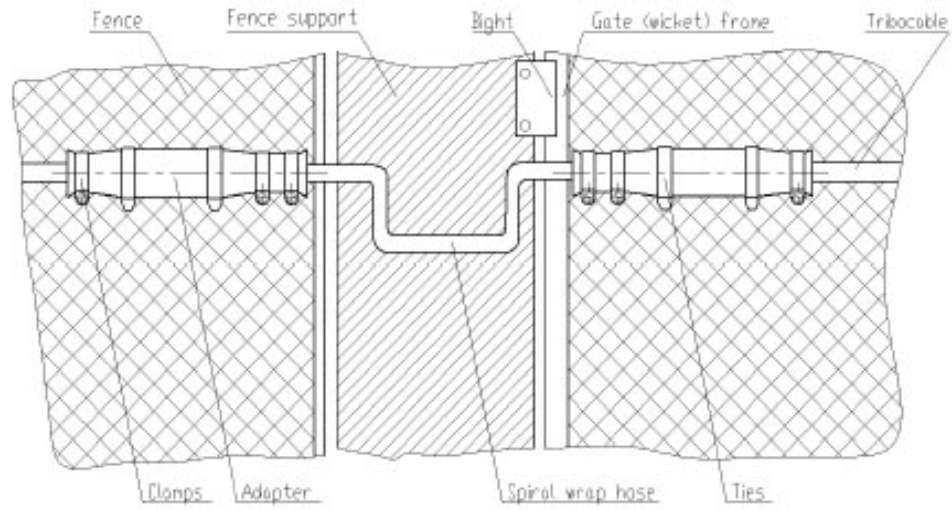
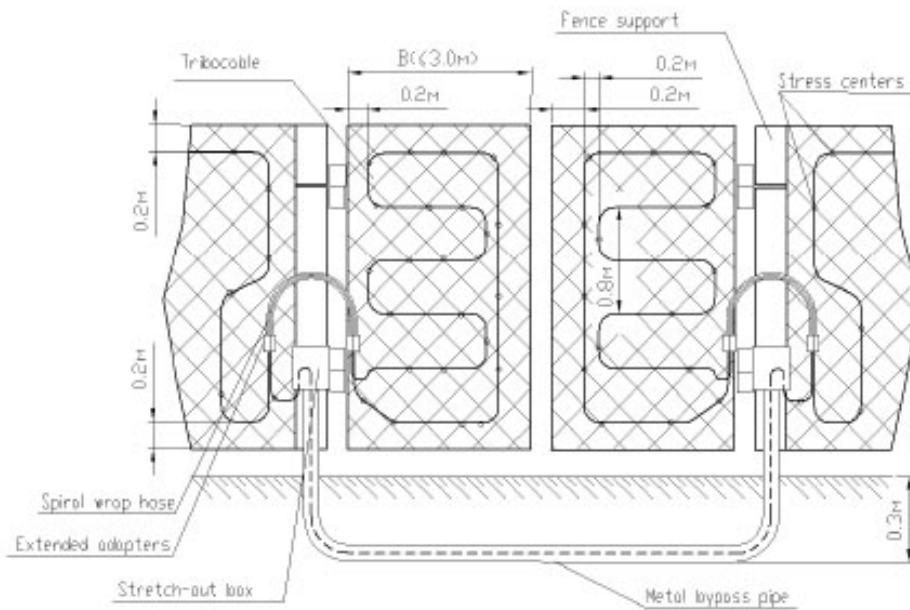

Fig.3a
Spiral Wrap Hose Mounting in Extended Adapter

- Fig.4 -
Equipping of Supports Extending Above Fence

